

Electronic Cruise Control for Kawasaki Concours Z1400GTR from 2010



The following provides a brief description of the power consumption and component locations of the MotorCycle Setup electronic cruise control.

Installed weight of the cruise control is approximately 2.5g.

Current draw while the cruise is switched on, but not engaged, is approximately 0.250 amp (3 watts). Current draw while the cruise is engaged is nominally 0.50~0.80 amp (6~10 Watts).

By comparison, a head light bulb typically draws about 4 amps (55 Watts), and a tail light bulb (running light) draws about 0.4 amp (5 Watts).

Refer to the line drawing on the back of this sheet to identify the component numbers in the text.

The **Computer (1)** mounts under the left side fairing inner panel, beside the left fork leg. A mounting bracket is provided in the kit to attached the computer to one of the left side mirror mounting studs. The photo is taken with the fairing removed.



The throttle servo or **Actuator (2)** mounts under the right side fairing inner panel, beside the right fork leg (photo below left). The **vacuum reservoir (3)** is also mounted here. The photo is taken looking down from above, with the fairing installed but with the instrument surround panel removed. We have a different version of the **Actuator (4)** for bikes equipped with an Evaporative Emissions Carbon Canister (California specification). The carbon canister is mounted where we put the actuator so an alternate mounting is required. The photo below right shows this with the right side main fairing panel removed. This photo is from a 2008 model bike. The bracket for the 2010 model bike is slightly different, but is essentially the same as the earlier models. A **vacuum hose assembly (5)** is provided to connect the actuator to the engine.



The **Cable Interface Unit (6)** is located on the left side of the motor, near the front left corner of the engine, above the coolant reservoir. It has a new **cable (7)** running from it to the fuel injection throttles.



The **Control Switch (8a)** is normally mounted to the left hand (clutch) master cylinder handlebar clamp.

The standard switch configuration supplied with the kit has the control switch mounted above the handlebar. The bracket mounts between the upper faces of the clamp and the master cylinder. The clamp must have about 2.0mm (0.080") filed from the top face to allow for the thickness of the switch bracket.



We also offer an alternate mounting bracket to mount the switch below the handlebar (**8b**). This is offered at no extra cost at time of ordering or the switch bracket may be purchased at any time.

The clamp must have about 1~1.5mm (0.040"~0.060") filed from the bottom face to allow for the thickness of the switch bracket.

While this option fits perfectly, when the handlebars are turned full left, there is very little clearance between the switch and the top of the plastic cover on the fuel tank. This could cause interference if a tank bag is fitted to the bike.



MotorCycle Cruise Controls

**6 Kingston Street
Mount Waverley VIC 3149
AUSTRALIA**

Web Site: <http://www.mccruise.com>

International: **Phone** (International Access Code) 61 3 9808 2804

Fax (International Access Code) 61 3 9808 2445

Australia: **Phone** (03) 9808 2804

Fax (03) 9808 2445

E-mail: sales@mccruise.com

The **Wiring Loom (9)** has the same type of plugs or terminals that are already used on the motorcycle. Power for the cruise control and brake sensing is taken off the brake light switches by unplugging the front brake light switch. Matching connectors on the cruise control loom are plugged in to the switch and the bike's loom. Speed sensing is sourced at the bike's speedometer sender using the same connection method. Tach (engine speed) sensing is detected from the bikes ignition wire to one of the ignition coils. This is used to disengage the cruise if the clutch is operated. The bike's clutch switch is also connected to the cruise control to disengage the cruise control. The cruise control is grounded on the battery negative terminal.

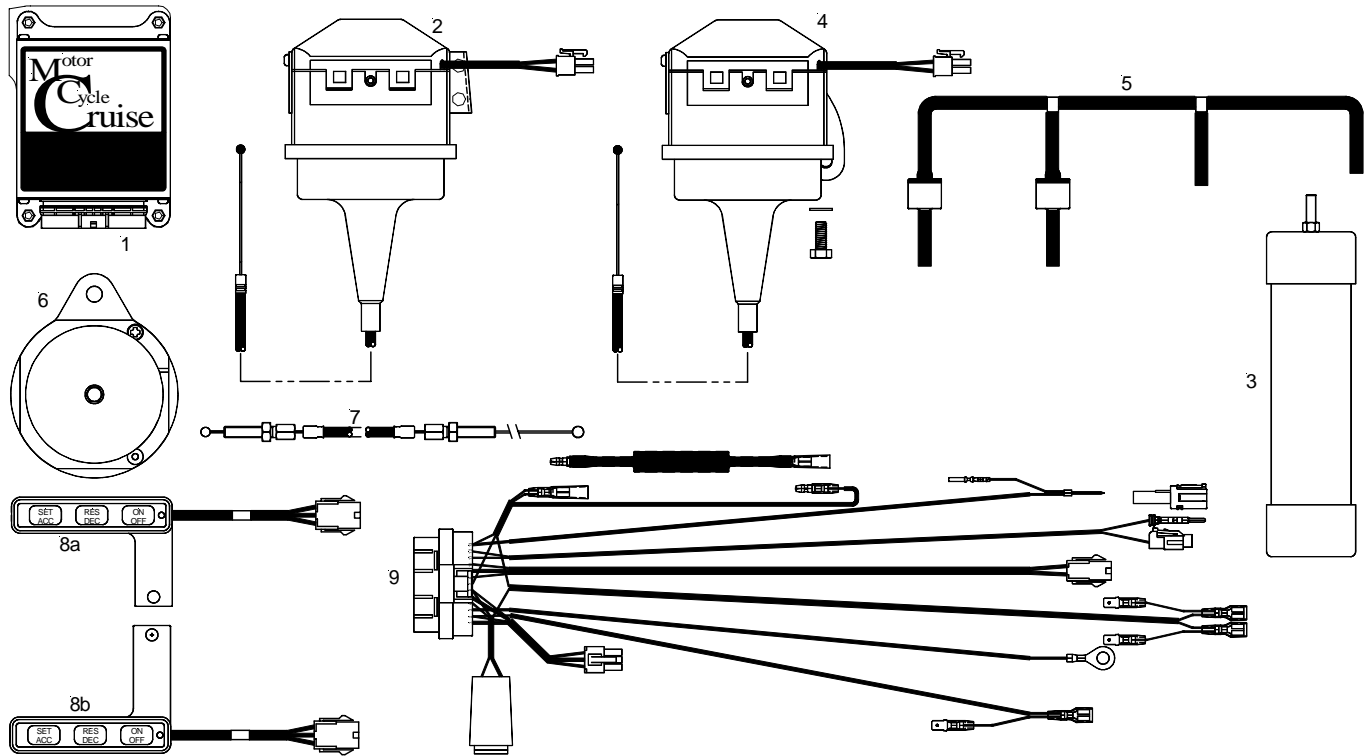

MotorCycle Cruise Controls

6 Kingston Street
Mount Waverley VIC 3149
AUSTRALIA

Web Site:

<http://www.mccruise.com>

International:

Phone (International Access Code) 61 3 9808 2804

Fax (International Access Code) 61 3 9808 2445

Australia:

Phone (03) 9808 2804

Fax (03) 9808 2445

E-mail: sales@mccruise.com