

Electronic Cruise Control for Yamaha XV1900A Roadliner and Stratoliner



The following provides a brief description of the power consumption and component locations of the MotorCycle Setup electronic cruise control.

Installed weight of the cruise control is approximately 2.0kg.

Current draw while the cruise is switched on, but not engaged, is approximately 0.250 amp (3 watts). Current draw while the cruise is engaged is nominally 0.50~0.80 amp (6~10 Watts).

By comparison, a head light bulb typically draws about 4 amps (55 Watts), and a tail light bulb (running light) draws about 0.4 amp (5 Watts).

Refer to the line drawing on the back of this sheet to identify the component numbers in the text.

The **Computer (1)** mounts under the seat. The tool bag and plastic tray (circled below) must be removed permanently from the bike. The computer is then mounted between the rear mudguard (fender) and the battery (arrowed at right), under the frame member that the tool tray bolts to. It is possible the tool bag may fit after the computer is fitted, but the tool tray will not.



The **Actuator (2)** is bolted to the left side of the engine using two of the crankcase cover bolts near the gear shift lever. Black powder coated aluminium covers are supplied to prevent dirt and water ingress into the actuator and to improve the appearance of the actuator. The actuator in these photos has covers that have been chrome plated. We can supply raw (un-painted) covers instead of the powder coated covers for customers who wish to have them chrome plated. We do not offer chromed covers. We do at times offer clear coated polished covers as an extra cost option.

A **Vacuum Hose assembly (3)** is provided to connect the actuator to the engine.

The **Cable Interface Unit (4)** is located on the left side of the motor, next to the front cylinder head. The CIU is supplied with a stainless steel cover to enhance its appearance. The CIU cover in these photos has been chrome plated. This cover is supplied in a finished (brushed) finish or satin finish as standard, but can also be supplied polished to a mirror finish as an extra cost option. We do not offer chrome plating.



The CIU has a new **cable (5)** running from it to the fuel injection throttles.

The **Control Switch (6)** is mounted to the left hand (clutch) master cylinder mirror mount.



The **Wiring Loom (7)** has the same type of plugs or terminals that are already used on the motorcycle. Power for the cruise control and brake sensing is taken off the brake light switches by unplugging the front brake light switch. Matching connectors on the cruise control loom are plugged in to the switch and the bike's loom. Speed sensing is taken from the bike's speedometer sender. Tach (engine speed) sensing is detected from the bike's ignition coils. This is used to disengage the cruise if the clutch is operated. The bike's clutch switch is also connected to the cruise control to disengage the cruise control. The cruise control is grounded on the battery negative terminal.

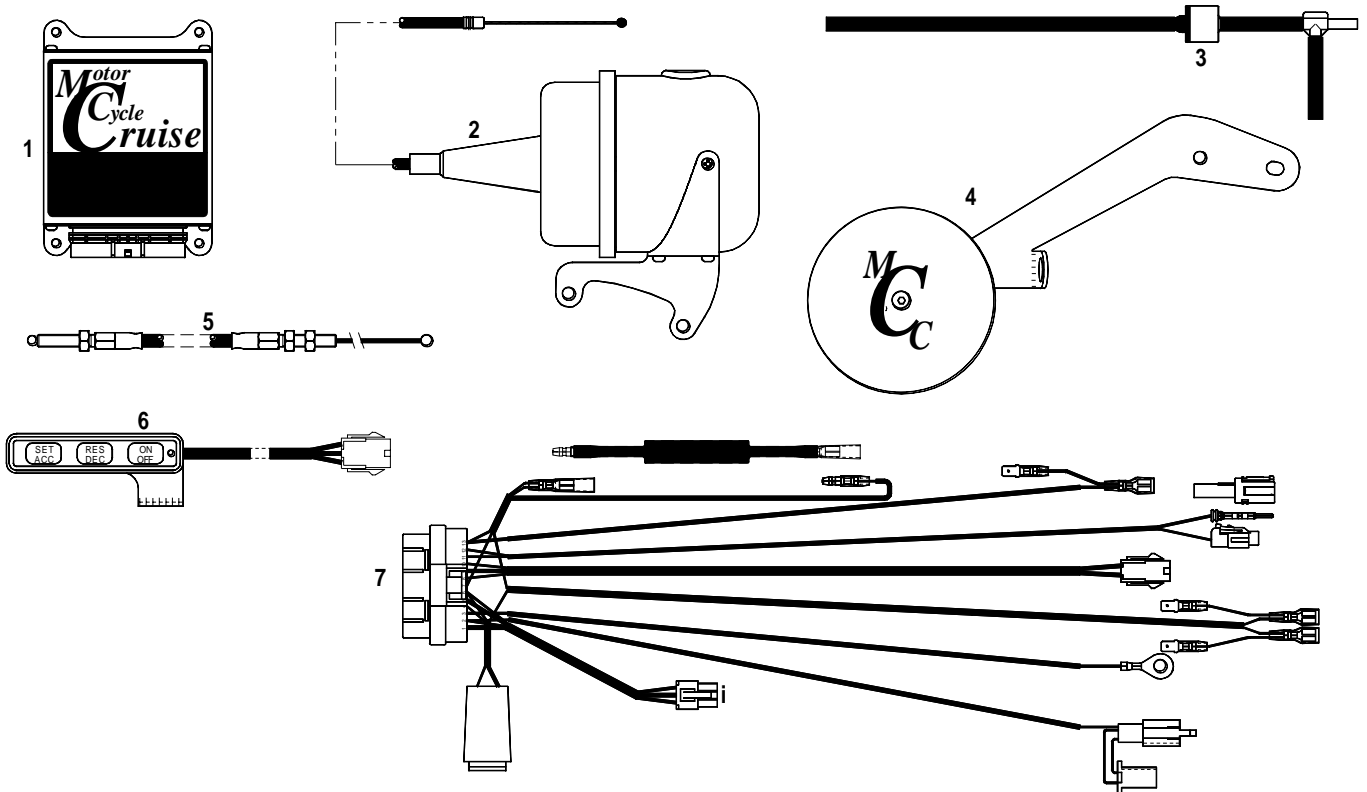

MotorCycle Cruise Controls

6 Kingston Street
Mount Waverley VIC 3149
AUSTRALIA

Web Site: <http://www.mccruise.com>

International: Phone (International Access Code) 61 3 9808 2804

Fax (International Access Code) 61 3 9808 2445

Australia: Phone (03) 9808 2804

Fax (03) 9808 2445

E-mail: sales@mccruise.com